

## FEATURES:

- Powered by 1-3 cell Alkaline or NiMH
- Ultra-low power
- Low cost
- Select 400/500V output
- Signal processing
- Output +5V DC for the periphery
- Simple use
- Supports most Geiger-Muller tubes
- Arduino compatible
- Input Polarity Protection

## EVM FOR:

- Geiger-Muller tubes
- Portable dosimeter
- Learning Geiger-Muller tube principle
- School or college electronics education

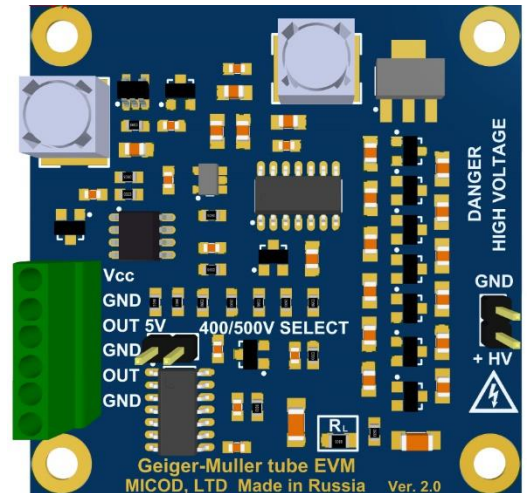

**Table 1 - ABSOLUTE MAXIMUM RATINGS**

Name	Value
Supply voltage, $V_{cc}$	+ 5.5 V
+5V output current without snubber circuit, $V_{cc} > 2V^{(1)}$	150 mA
+5V output current with snubber circuit, $V_{cc} > 2.5V^{(1,2)}$	400 mA

**Table 2 - SPECIFICATIONS**

Name	Min.	Recommended/ Set-point	Max.
Supply voltage	+1.5 V		+5 V
High voltage output		400/500 V $\pm 7\%$	
Periphery output DC voltage		+5 V	
Current consumption (no load, no GM tube, $V_{cc}=5V$ ) <sup>(3)</sup>		~100/100 $\mu A$	
Current consumption (no load, no GM tube, $V_{cc}=1.5V$ ) <sup>(3)</sup>		~370/445 $\mu A$	
Signal output time constant		10 $\mu S$	
Signal output level		+5V	
Current limiting resistor for Geiger-Muller tube ( $R_L$ )		10 M $\Omega$	
Weight, grams			15

- (1) The maximum output current depends on the supply voltage. The higher the voltage - the higher the output current.
- (2) Maximum output current possible if available snubber circuit. A snubber circuit consisting of a resistor R and a capacitor C and Schottky diode D (ZHCS1000TA recommended). The typical value of the resistor R is 5  $\Omega$ , and the typical value of the capacitor C is 120 pF. **Snubber circuit increases total current consumption!**
- (3) Quiescent current with/without snubber circuit

## QUIESCENT CURRENT

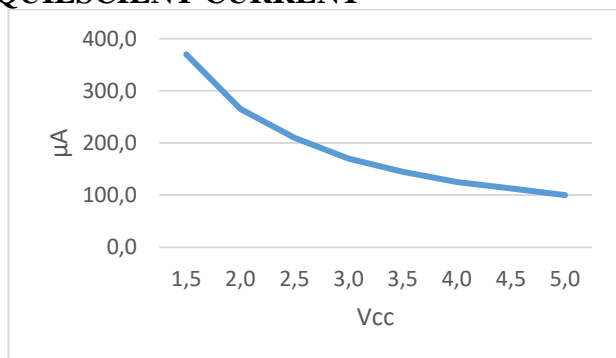

Fig. 1. Quiescent current without snubber circuit.

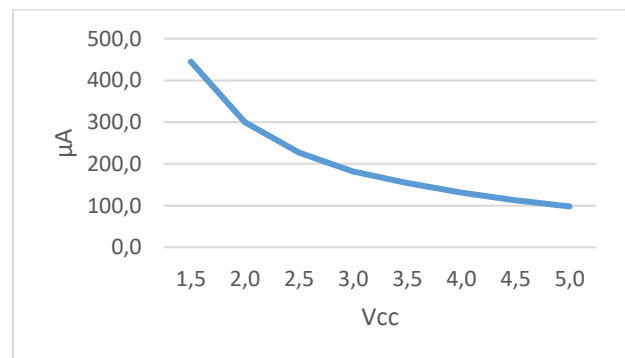

Fig. 2. Quiescent current with snubber circuit.

## WARNING



High voltage power supply is extremely dangerous device!

Forbidden the operation or adjustment of the power supply to people using pacemaker or other electronic life support devices! Remember that after turning off the power supply, the HV outputs voltage is still some time present! The manufacturer is not responsible for any consequences use of the device, including damage to equipment / fire / injury / disability or death! With a small gap it is possible electric arcing that can cause fire and damage equipment or power supply failure.

## EVM

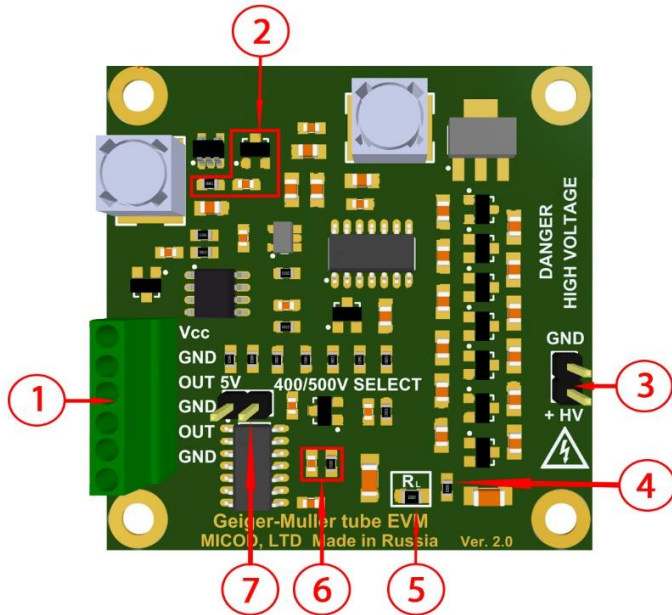

Fig. 3. EVM board<sup>(1)</sup>.

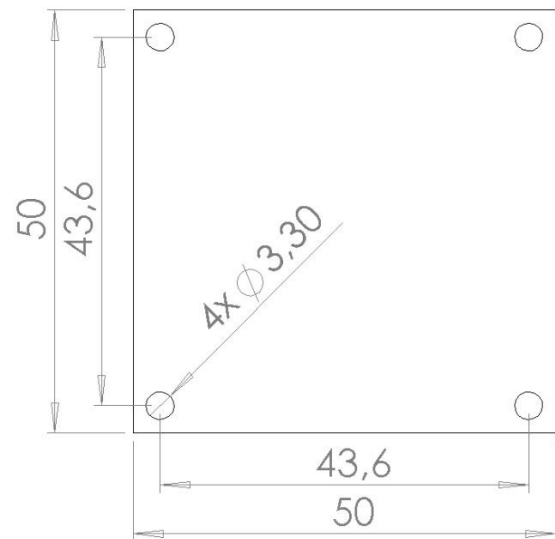

Fig. 4. EVM board dimensions.

- 1 Main connector (+Vcc, GND, Out DC +5V, GND, Signal OUT, GND);
- 2 Snubber circuit (option);
- 3 Geiger-Müller tube connector (HV OUTPUT!);
- 4 High voltage control point;
- 5 Current limiting resistor, typical 10 MΩ;
- 6 RC circuit forming the output pulse duration;
- 7 Switching output voltage: Open: 400V, Shorted: 500V.

(1) PCB Color or Surface Finish done at the discretion of the manufacturer. Typically: PCB Color- white, Surface Finish-ENIG.

## SIGNAL OUTPUT

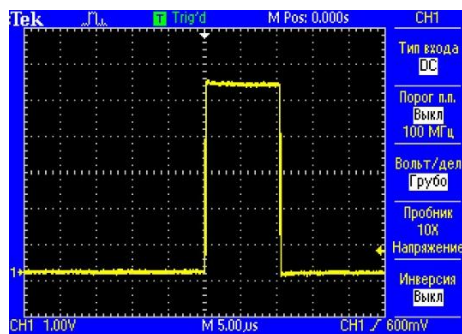

Fig. 5. The form of the output signal